

## Polarizing Optics

### Waveplates:

Waveplates (retardation plates or phase shifters) are made from materials which exhibit birefringence. The velocities of the extraordinary and ordinary rays through the birefringent materials vary inversely with their refractive indices. The difference in velocities gives rise to a phase difference when the two beams recombine. In the case of an incident linearly polarized beam this is given by  $\alpha = 2\pi d(n_e - n_o) / \lambda$  ( $\alpha$ -phase difference;  $d$ -thickness of waveplate;  $n_e, n_o$ -refractive indices of extraordinary and ordinary rays respectively;  $\lambda$ -wavelength). At any specific wavelength the phase difference is governed by the thickness of the retarder.

### True Zero-Order Waveplate:

#### Single Plate True-Order Waveplate(SWP)

##### Specifications:

Material: Optical grade Quartz Crystal  
 Dimension Tolerance: +0.00, -0.20 mm  
 Clear Aperture: >80%  
 Surface Quality: 10 – 5 Scratch & Dig  
 Parallelism: <1"  
 Chip: <0.3 mm  
 Wavefront Distortion: < $\lambda/10$  @632.8nm  
 Retardation Tolerance: < $\lambda/300$   
 $\lambda/2$  Waveplate  
 Standard Wavelength: 1550 nm  
 Coating: AR coating,  $R < 0.2\%$  @1550nm

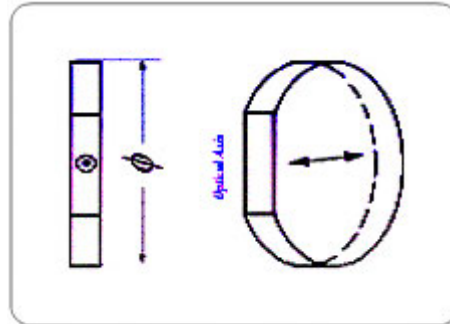

Part No.	Material	$\Phi$ (mm)
SWP1110	Quartz Crystal	10.0
SWP1112	Quartz Crystal	12.7
SWP1115	Quartz Crystal	15.0
SWP1120	Quartz Crystal	20.0

#### Low-Order Waveplate (LWP)

##### Specifications:

Material: Optical grade Quartz Crystal  
 Dimension tolerance: +0.00, -0.20 mm  
 Clear Aperture: >80%  
 Surface Quality: 10 – 5 Scratch & Dig  
 Parallelism: <1"  
 Chip: <0.3 mm  
 Wavefront Distortion: < $\lambda/10$  @632.8nm

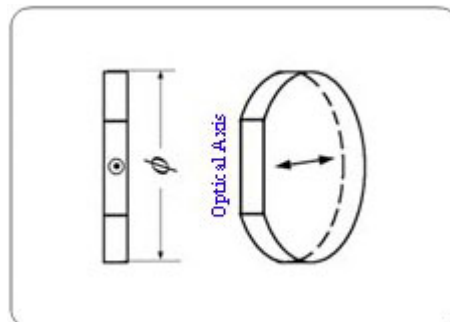

Retardation Tolerance:  $<\lambda/500$

Part No.	Material	$\Phi$ (mm)	Thickness(mm)
LWP1110	Quartz Crystal	10.0	0.2~0.4
LWP1112	Quartz Crystal	12.7	0.2~0.4
LWP1115	Quartz Crystal	15.0	0.2~0.4
LWP1120	Quartz Crystal	20.0	0.2~0.4
LWP1125	Quartz Crystal	25.4	0.2~0.4

We can provide this kind of waveplates with  $\lambda/8$  order,  $\lambda/4$  order or  $\lambda/2$  order Wavelength within the range of 240 nm~2100 nm are available upon request

Coating: AR coating,  $R<0.2\%$  at the center of wavelength

### Low-Order Waveplate(LWP)

#### Specifications:

Material: Optical grade Quartz Crystal Dimension tolerance:  $\pm 0.05$  mm

Thickness tolerance:  $\pm 0.00029$  mm

Clear Aperture:  $>80\%$

Surface Quality: 10 – 5 Scratch & Dig

Parallelism:  $<3''$

Chip:  $<0.3$  mm

Wavefront Distortion:  $<\lambda/10$  @632.8nm

Retardation Tolerance:  $<\lambda/300$

Standard Wavelength: 1550nm

Coating: AR coating,  $R<0.2\%$ @1550nm

Part No.	Material	X(mm)	Y(mm)	t(mm)	Order
LWP1431	Quartz	2.50	2.50	0.1370	$3\lambda/4$
LWP1432	Quartz	3.20	3.20	0.1370	$3\lambda/4$
LWP1871	Quartz	2.50	2.50	0.1598	$7\lambda/8$
LWP1872	Quartz	3.20	3.20	0.1598	$7\lambda/8$

### Zero-Order Waveplates:

#### Cemented/Optically contacted Zero-Order Waveplates(OWP)

#### Specifications:

Material: Optical grade Quartz Crystal

Dimension Tolerance:  $+0.00, -0.20$  mm

Clear Aperture:  $>80\%$

Surface Quality: 10 – 5 Scratch & Dig

Parallelism:  $<1''$

Chip:  $<0.3$  mm

Wavefront Distortion:  $<\lambda/10$  @632.8nm

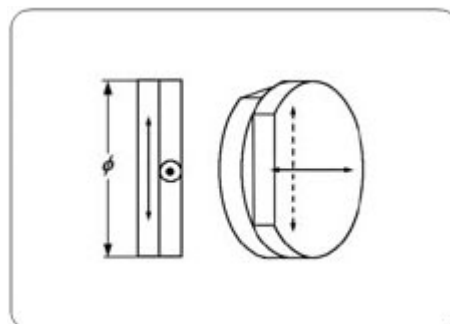

Retardation Tolerance:  $< \lambda/300$

Cemented Zero-Order			Optically Contacted Zero-Order		
Part No.	Material	$\Phi$ (mm)	Part No.	Material	$\Phi$ (mm)
OWP1110	Quartz	10.0	OWP1210	Quartz	10.0
OWP1112	Quartz	12.7	OWP1212	Quartz	12.7
OWP1115	Quartz	15.0	OWP1215	Quartz	15.0
OWP1120	Quartz	20.0	OWP1220	Quartz	20.0
OWP1125	Quartz	25.4	OWP1225	Quartz	25.4

We can provide this kind of waveplates with  $\lambda/4$  order or  $\lambda/2$  order Wavelength within the range of 240 nm~2100 nm are available upon request

Coating: AR coating,  $R < 0.2\%$  at the center of wavelength

### Multi-Order Waveplate

#### Specifications:

Thickness: 1 mm

Single plates

High Damage Threshold

Low Cost

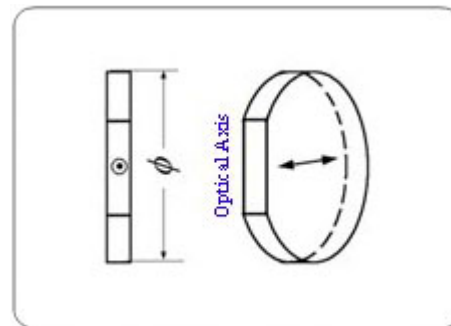

Part No.	f(mm)Uncoated	Part No.	f(mm)AR/AR coated
WPM1110	10.0	WPM1210	10.0
WPM1112	12.7	WPM1212	12.7
WPM1115	15.0	WPM1215	15.0
WPM1120	20.0	WPM1220	20.0
WPM1125	25.4	WPM1225	25.4