



ST60 TO-5 & ST60R TO-5 With Diffractive Lens

Silicon Based Thermopile Detector

Features: A single-channel silicon-based thermopile with integrated diffractive lens and internal baffle that provides lowest cost solutions in a small active area of 0.61mm x 0.61mm in a TO-5 package. Time constant of 18ms with Nitrogen encapsulation gas and 9° FOV. Delivers a very low Temperature Coefficient of Responsivity of -0.01%/°C. This detector has a very short thermal shock response to ambient temperature change.

Options: **1) ST60R TO-5** version offers a low-cost (20% tolerance) poly-silicon resistor to be used as a PTC thermistor. **2) Internal 30k \pm 5% NTC chip thermistor** provides ambient package temperature measurement. See [Thermistor Options](#) p/n: MT04. See [Thermopile Configuration Table](#) for more options.

Applications: Excellent for 9° FOV non-contact temperature measurement

Benefit: Low cost, narrow FOV, and small active area size with medium output.

Technical Specifications

Specifications apply at 23°C with AR coated Diffractive Lens (P/N: DC-6132) and Nitrogen encapsulating gas

Parameter	Min	Typical	Max	Symbol	Units	Comments
Active Area size	.61 x .61			AA	mm	Hot junction size, per element.
Element Area	.37			A	mm ²	
Number of Junctions	80					Per element.
Number of Channels	1					Per detector package.
Output Voltage	240	295	350	V _s	µV	DC, H=330µW/cm ² (3)
Signal-to-Noise Ratio	6,630	9,425	13,672	SNR	vHz	DC, SNR=V _s /V _n
Responsivity	195.5	240.2	285.0	R	V/W	DC, R=V _s /H A (2)
Resistance	40	60	80	R	k Ω	Detector element
Temperature Coefficient of R		-.01			%/°C	Best linear fit, 0° to 85°C (1)
Temperature Coefficient of R		.11			%/°C	Best fit, 0° to 85°C (1)
Noise Voltage	25.6	31.3	36.2	V _n	nV/√Hz	V _n ² =4kTR
Noise Equivalent Power	.09	.13	.19	NEP	nW/√Hz	DC, NEP= V _n H A/V _s (2)
Detectivity	3.30	4.68	6.80	D*	10 ⁶ cm ² Hz/W	DC, D*=V _s / V _n H? A (2)
Time Constant		18		T	ms	Chopped, -3dB point (1)
Field of View	9°			FOV	Degrees	See Assembly Drawings for FOV Description.
Package Type	TO-5 with Lens					Standard package hole size: ? .150"
Operating Temperature	-50		100	T _a	°C	
ST60R Thermistor Option	-24	30	-36	R _T	k Ω	PTC Poly-Silicon resistor on detector die.
ST60R Thermistor Temperature Coefficient of R	.107	.11	.113		%/°C	? R/(R? T), Best fit, 0° to 85°C (1)

General Specifications: Flat spectral response from 100nm to > 100µm. Linear signal output from 10⁻⁶ to 0.1W/cm². Maximum incident radiance 0.1W/cm², damage threshold = .5W/cm²

Notes: (1) Parameter is not 100% tested. 90% of all units meet these specifications. (2) A is detector area in cm². (3) Test Conditions: 500K Blackbody source; Detector active surface 10cm from 0.6513cm Diameter Blackbody Aperture.

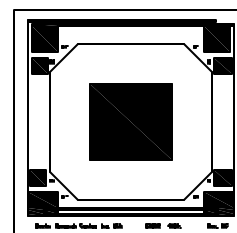

Detector circuit overlay



ST60 TO-5

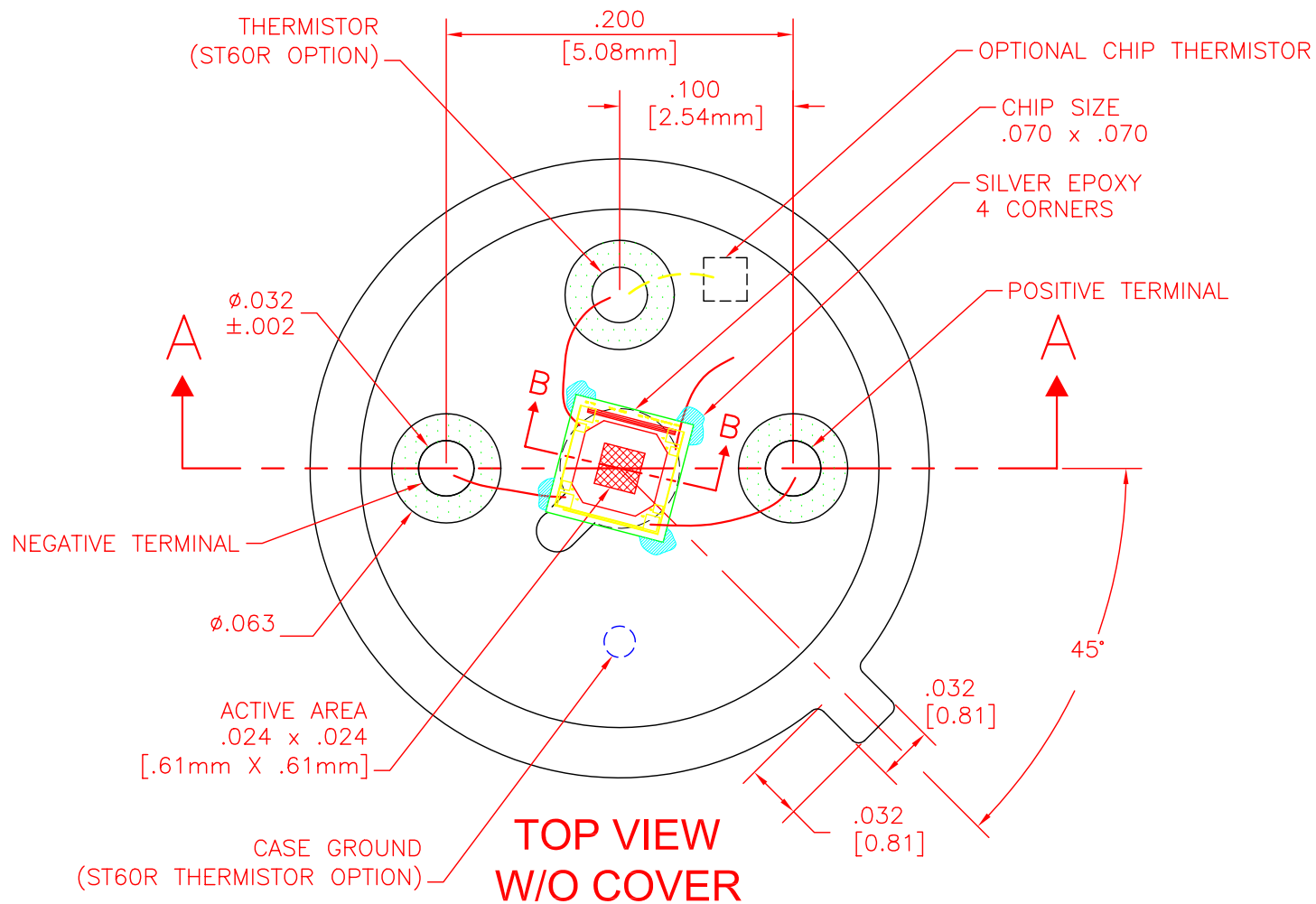

UNLESS OTHERWISE SPECIFIED, ALL DIMENSIONS ARE IN INCHES.
TOLERANCES ARE:

FRACTIONS	DECIMALS	ANGLES
±	.XX ± .01	±
	.XXX ± .005	

APPROVALS	DATE
DRAWN: DLJ	3/29/04
CHECKED:	
ENGINEERED:	
APPROVED:	

DEXTER RESEARCH CENTER, Inc.
7300 Huron River Dr., Dexter, MI 48130, ph. 734-426-3921 fax 734-426-5090

ASSEMBLY, ST60/ST60R, TO-5 RW, TOP VIEW

SIZE:	SCALE:	DWG. NO.	REV.	PAGE:
A	10" = 1"	1023.3	D	2 OF 2
DRC PART NO.		MATERIAL:	FINISH:	

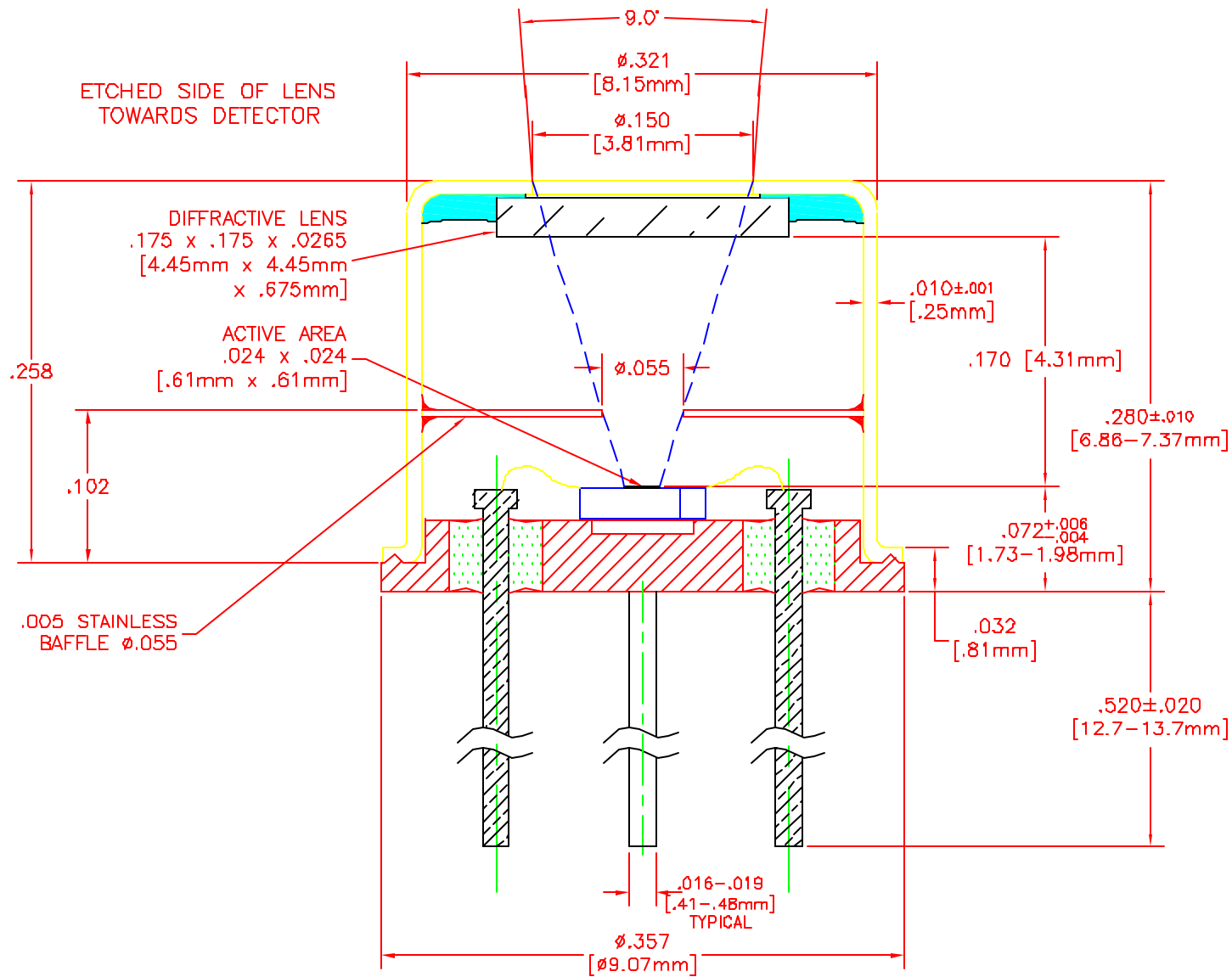

UNLESS OTHERWISE SPECIFIED, ALL DIMENSIONS
ARE IN INCHES.
TOLERANCES ARE:
FRACTIONS DECIMALS ANGLES
± .XX ± .01 ±
± .XXX ± .005 ±

APPROVALS	DATE
DRAWN: DLJ	8/18/05
CHECKED:	
ENGINEERED:	
APPROVED:	

DEXTER RESEARCH CENTER, Inc.

7300 Huron River Dr., Dexter, MI 48130, ph. 734-426-3921 fax 734-426-5090

ASSEMBLY, ST60/R, DIFFRACTIVE
LENS, 4.40mm FOCAL LENGTH

SIZE: A	SCALE: 9" : 1"	DWG. NO. 1064	REV. F	PAGE: 1 OF 1
DRC PART NO.		MATERIAL:		FINISH: